

# HVAC VFD Quickstart Guide



## Wiring

Warning: Input, Output and Control wiring must be in separate conduits  
 Note: **Do not** wire any wire to the DC bus "P1", "P2" & "N" terminals.

### VFD Only

Verify correct input voltage and wiring to the VFD power and motor terminals. Connect 3-phase input power wires to VFD terminals **R, S & T** or single-phase power wires to VFD terminals **R & S**. Connect 3-phase motor wires to VFD terminals **U, V & W**. Connect power source ground wire and motor ground wire to VFD ground terminal.

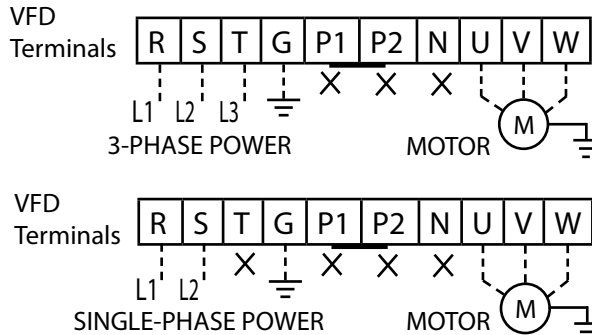

### Enclosed VFD

Verify correct input voltage and wiring to enclosed VFD panel power and motor terminals. Connect 3-phase input power wires to enclosure or disconnect terminals **L1, L2 & L3** or single-phase power wires to terminals **L1 & L2**. Connect 3-phase motor wires to enclosure terminals **T1, T2 & T3**. Connect power source ground wire and motor ground wire to enclosure ground terminal.

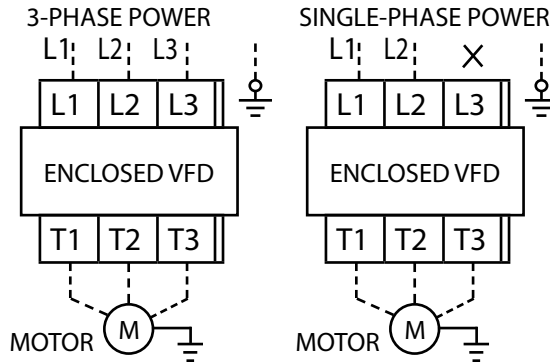

### BMS Control Wiring:

Use shielded cable with shield connected on VFD side to analog common or chassis ground for better noise protection in analog signal circuitry.  
**0-10VDC.** Connect BMS 0-10VDC output positive wire to the VFD terminal marked **V1** and negative to terminal **5G** for 7.5-40HP VFDs and **CM** for 50-700HP VFDs.  
**4-20mA.** Connect BMS 4-20mA output positive wire to the VFD terminal marked **I** and negative to terminal **5G** for 7.5-40HP VFDs and **CM** for 50-700HP VFDs.  
 For enclosed VFD with terminal block connect negative wire to **AG** terminal.  
**Run Command.** Connect run signal wires to VFD terminals **CM** and **M7**.  
**Run Status.** Connect run status signal wires to VFD terminals **A1** and **C1** (N.O. relay contact).  
**VFD Frequency.** Connect VFD frequency 0-10VDC output signal terminal **S0** to BMS positive wire and **5G** to negative wire.  
**VFD Fault.** Connect fault signal wires to VFD terminals **3A** and **3C** (N.O. relay contact)

### Transducer Wiring:

**0-10VDC Transducer.** Wire the pressure transducer's positive (POWER) wire to the VFD terminal marked **V+** for 12VDC or **24** for 24VDC, negative (COM) wire to VFD terminal **5G** for 12VDC and **CM** (CM should be jumpered to 5G) for 24VDC and the output (0-10V Out) wire to terminal **V1** with the shield wired to **5G** for 7.5-40HP VFDs or **CM** for 50-700HP VFDs.

**4-20mA Transducer.** Wire the pressure transducer's positive (POWER) wire to the VFD terminal marked **V+** for 12VDC or **24** for 24VDC, negative (COM) wire to VFD terminal **5G** for 12VDC and **CM** (CM should be jumpered to 5G) for 24VDC and the output (4-20mA Out) wire to terminal **I** with the shield wired to **5G** for 7.5-40HP VFDs or **CM** for 50-700HP VFDs.

0-10VDC, 12 VDC Power

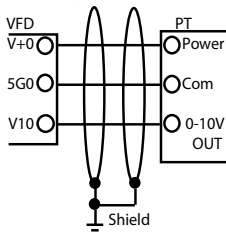

0-10VDC, 24 VDC Power

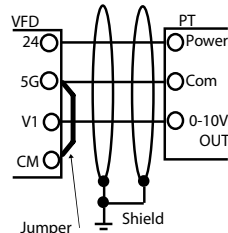

4-20mA, 12 VDC Power

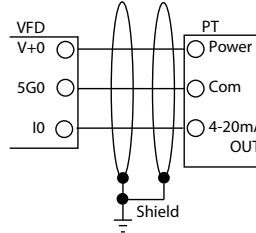

## Keypad Programming

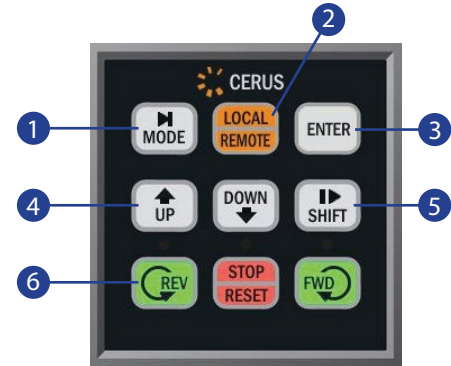

- Mode:** Use to cycle through parameter groups: SET>DRV>FG1>FG2>...>SET>..
- Loc/Rem:** Toggles between Local and Remote operation. In Local letter **L** will be displayed next to the parameter code #.
- Enter:** Use to enter or exit programming mode of any parameter. A flashing cursor will appear when VFD is in programming mode.
- Up & Down:** Use to cycle through parameters of the current group or to adjust parameter value or change selection when in programming mode.
- Shift:** Use to cycle backwards through parameter groups. When in programming mode, use to shift cursor to the right (one position per press) when changing digits in numerical value.
- Rev, Stop/Reset & Fwd:** Use to Start and Stop VFD Forward or Reverse in Local mode. Use **Stop** to reset VFD fault.

### Main Display:

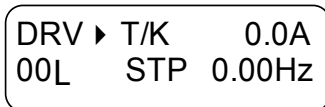

**DRV** - Current parameter group. (SET, DRV, FG1, FG2, I/O, APP, EXT & COM)

**00L** - Shows the current parameter number within a current group. An 'L' will appear when VFD is switched to Local control mode by either LOC/REM key or digital input.

**T** - Shows source for VFD start/stop operation (T = Remote, K = Keypad, O = Communication Protocol).

**K** - Shows source for VFD frequency command (K= Keypad, V= 0-10VDC, I= 4-20mA, O= Communication)

**0.0A** - Shows the actual motor current

**STP** - Shows the current status of the VFD (STP = Stop, FWD = Forward, REV = Reverse)

**0.00Hz** - Shows frequency reference or PID set-point in VFD stop mode and actual VFD output frequency in VFD run mode.

## BMS or Transducer Signal Verification:

V1	1240	V2	0
VIS	0	I	3980

Press [▼] key from the main display DRV-00 until you see display with analog inputs V1, V2, V1S, and I. The readings shown on this display are raw AD converter values from 0 to approximately 4095.

**4-20mA.** Divide I value by 337 and result will be a mA value. This value should be more than 800 if not, verify transducer wiring.

**0-10VDC.** Divide V1 value by 204 and result will be a VDC value. Compare this value to voltage on VFD terminals V1 and 5G or CM (based on VFD HP rating).

If signal has some electrical noise, increase setting for filter time in parameter I/O- 01 for 0-10VDC and I/O-06

## System Initial Start Up & Control Settings

The majority of drive setups can be accomplished by going through only one group; the setup [SET] group. This group was designed to have start-up specific parameters to make start-up easy. Navigate to the SETUP group [SET] by pressing the SHIFT button once from the main screen. Your display will show SET in the upper left hand corner of the display.

### Parameter Programming Description

- 1) Press the [MODE] or [SHIFT] key until the desired parameter group is displayed.
- 2) Press UP [▲] or DOWN [▼] keys to scroll to the desired parameter. If you know the desired parameter number, you can set its number in the first parameter #00 "Jump code" of any parameter group (except SET and DRV groups) and after pressing [ENTER] key display will show that parameter.
- 3) Press [ENTER] key to enter the programming mode, which is indicated by a flashing cursor. Some parameters cannot be changed during VFD run or fault modes. Refer to the manual to check if desired parameter can be programmed during run.
- 4) For selectable parameters press [▲] or [▼] keys to change parameter selection.  
When programming a numerical value, the value will be changed from maximum to minimum by pressing [▲] or [▼] key. In order to change any digit in a numeric value, use the [SHIFT] key to move the flashing cursor to that digit and [▲] or [▼] key to adjust the selected digit.
- 5) Press [▲] or [▼] keys to change the digit in numerical parameter value.
- 6) Press [ENTER] key to finish programming for this parameter. The flashing cursor disappears.

## Verify Basic Settings

SET ▶ App. Select
00      None

**Application Selection:** Select [BASIC] application if VFD is controlled by BMS, or [FAN] if it is wired to pressure transducer. Refer to the parameter table at the end of this quick-start for presets.

SET ▶ Input Phase
01      3-Phase

**Input Power # of Phases:** Default is 3-Phase. Select 1-Phase for single-phase to three-phase conversion application which will change a motor HP rating setting to 50% of the VFD rating.

SET ▶ Motor HP
02      7.5 HP

**Rated Motor HP:** Enter the motor horsepower rating from the motor nameplate.

SET ▶ Motor FLA
03      2.2 A

**Rated Motor Current:** Enter the motor FLA (Full Load Amps) rating from the motor nameplate.

SET ▶ Low Limit
13      20.00 Hz

**Frequency low Limit:** Default setting is 20.00Hz which is enough to provide some cooling air flow for the motor. It can be changed from 0.00Hz to Maximum Frequency.

## Verify Motor Shaft Rotation

Move HOA switch knob to HAND position and the VFD will begin to run the motor. Check the output airflow and verify proper rotation. If rotation is incorrect, stop VFD by putting HOA in OFF position, turn the VFD power off and wait minimum 5 minutes. Swap any two motor leads to change rotation (swapping input power wires will not change the motor rotation).

## Advanced Control Features

These parameters with optimal and safe settings Exhaust or Supply Fan application are not enabled by default and can be enabled at any time. You may need to adjust some parameters to provide better control for your system.

### PID (Proportional Integral) Control with Pressure Transducer

SET ▶ PID Mode  
20 Yes

**PID Enable.** The PID control allows the VFD to maintain a process value (pressure, temperature etc.) by varying the output frequency based on the difference between a set point and actual feedback (transducer signal) value. The SET-20 parameter enables the internal PID control.

SET ▶ PID F/B  
21 I

**PID Feedback.** Select pressure transducer output type: I for 4-20mA or V1 for 0-10VDC. If transducer signal has some electrical noise, increase setting for filter time in parameter I/O- 01 for 0-10VDC and I/O-06 for 4-20mA. Default selection is I for 4-20mA.

SET ▶ F/B Unit Max  
25 1.00 inWC

**Transducer Range.** Set a pressure transducer range. Example: If transducer range is 0-2.5inWC, enter 2.50inWC in parameter SET-25. Default setting is 1.00inWC.

SET ▶ PID SetPoint  
26 0.25 inWC

**PID Set-point.** Set a desired pressure in parameter SET-26. The VFD will maintain this pressure by changing the speed of the motor. Default setting is 0.00inWC

SET ▶ PID Limit-L  
27 20.00 Hz

**PID Frequency Low Limit.** Set a low limit for VFD output with PID control in parameter SET-27. Default setting is 20.00Hz

### UnderLevel Protection (Belt Loss)

Underlevel trip (known as Belt Loss protection) is designed to trip the VFD when the motor current draw is less than SET-78 for SET-77 time delay when VFD output frequency is above SET-76. For Fan application it is typically 30-35% of the motor FLA.

SET ▶ Level Detect  
74 Under Level

**Level Detection Selection:** Change SET-74 from NO to UnderLevel to enable Belt Loss protection.

SET ▶ LDT Delay  
77 2 sec

**Level Detection Delay:** SET-77 is a delay before VFD trips on Underlevel fault.

SET ▶ LDT Level  
78 0.0 A

**Level Detection Level:** If motor nameplate does not show a no-load current, set parameter SET-78 to 30-35% of motor FLA or below the run current at minimum speed.

## System Operation Validation

### STAND ALONE VFD

1. Press Local/Remote key to switch to local control mode (letter L should appear next to the parameter code #. The VFD should behave based on SET-90 setting for LOC/REM key selection. Start VFD by pressing FWD key. The VFD should start and run at speed set in DRV-00 parameter or at minimum speed limit if Hand mode speed is too low. Increase speed to 60Hz and run for a minute. The motor current should be less than motor FLA rating.
2. Press Stop key. The VFD should stop based on Stop Mode selection (Deceleration or Free Run).
3. Press Local/Remote key and when start contact from BMS is closed, the VFD will start and run at speed set by BMS or at minimum speed limit if BMS signal is too low.
4. If VFD follows BMS speed signal up but does not properly follow it down, there is a high level of electrical noise in analog signal. Check analog cable shield connection and increase filter time in parameter I/O- 01 for 0-10VDC and I/O-06 for 4-20mA. If everything works good, your VFD is ready for normal operation.

### ENCLOSED VFD

1. Put HOA switch in Hand position. The VFD should start and run at speed set in DRV-00 parameter or at minimum speed limit if Hand mode speed is too low. Increase speed to 60Hz and run for a minute. The motor current should be less than motor FLA rating.
2. Put HOA switch in OFF position. The VFD should stop based on Stop Mode selection (Deceleration or Free Run).
3. Put HOA switch in AUTO position and when start contact from BMS is closed, the VFD will start and run at speed set by BMS or at minimum speed limit if BMS signal is too low.
4. If VFD follows BMS speed signal up but does not properly follow it down, there is a high level of electrical noise in analog signal. Check analog cable shield connection and increase filter time in parameter I/O- 01 for 0-10VDC and I/O-06 for 4-20mA. If everything works good, your VFD is ready for normal operation.

## Saving Parameters

Saving parameters to the keypad is recommended after the start-up is performed and you are satisfied with pump system operation. If the programming is changed later and your VFD is no longer operating the way you intended it to, you can always load your previously saved parameters from the keypad. Additionally, the programmed keypad can be used to copy same parameter settings to another VFD.

FG2 ▶ Para.Read  
91 Yes

**Save Parameters to Keypad:** Change FG2-91 to YES to save parameters to the keypad. After pressing ENTER key, this parameter will go back to NO after saving is done (approximately one minute).

FG2 ▶ Para.Write  
92 Yes

**Load Parameters from Keypad:** Change FG2-92 to YES to load parameters from the keypad. After pressing ENTER key, this parameter will go back to NO after loading is done (approximately one minute).

## Factory Programmed Parameters

Function	Parameter	Description	Basic	Supply Fan	Exhaust Fan
	SET-11	VFD acceleration time	20 sec	20 sec	20 sec
	SET-12	VFD deceleration time	10 sec	30 sec	30 sec
	SET-16	Stop mode	Coast	Coast	Coast
PID Control	SET-20	PID Operation	No	No	No
	SET-21	PID Feedback Signal	I (4-20mA)	I (4-20mA)	I (4-20mA)
	SET-22	Feedback unit	Cust	inWC	inWC
	SET-25	Transducer Range	100.0	1.00 inWC	1.00 inWC
	SET-26 & DRV-00	PID Set-Point	50.0	0.50 inWC	0.50 inWC
	SET-27	PID low limit frequency	20.0Hz	20.0Hz	20.0Hz
Underload Belt Loss	SET-74	Level detection enable	No	No	No
	SET-75	Level detection source	Current	Current	Current
	SET-76	Level detection frequency	59.0Hz	59.0Hz	59.0Hz
	SET-77	Level detection delay time	2sec	2sec	2sec
	SET-78	LDT Level	0.0A	0.0A	0.0A
	SET-80	Level detection trip enable	No	No	No